



# EUROFID3010 TOTAL HYDROCARBON ANALYZER

Continuous monitoring of the lower explosion limit (LEL)

Extractive gas analyzers

**SICK**  
Sensor Intelligence.

# Specialist for the measurement of the lower explosion limit (LEL) of total hydrocarbons

The EuroFID3010 total hydrocarbon analyzer is the specialist for the continuous monitoring of the lower explosion limit (LEL) of hydrocarbon mixtures. The integrated sample gas dilution, short response time, and design with no moving parts ensure high availability and, above all, fast and reliable information about your process. The EuroFID3010 is modular and can be configured in a system consisting of the following components: analyzer unit, control unit, and terminal box. Additional options, such as the Ex 1 industrial enclosure, enable the system to be adapted to handle challenging tasks.

The EuroFID3010 from SICK is approved as a gas warning device in accordance with the latest version of the EN 50271:2010 standard.



### Quick availability

The EuroFID3010 is attached directly to the plant via a flange. The sampling pipe extends directly into the process chamber. The fast supply of sample gas through the ejector pump and the measurement principle of the EuroFID3010 ensure a short response time ( $T_{90}$ ), allowing you to detect changes in the process very quickly and react to them accordingly.

### Integrated dilution

The sample gas is diluted using the ejector principle, enabling measurements of gas mixtures which would solidify if left undiluted to be taken. Dilution also allows high concentrations to be measured.

### No moving parts

The EuroFID3010 measures continuously and has no moving parts. An ejector pump is used instead of a mechanical pump to supply the sample gas. Wear and mechanical failures are not an issue. This results in lower maintenance costs (low cost of ownership).

### Adaptation to process conditions

The EuroFID3010 offers various options as a system. These include the industrial enclosure for Ex and non-Ex applications, the process gas lock-out, and the flexible positioning of the control unit at a distance of up to 500 m from the analyzer unit.

### Heating

All of the parts of the device that come into contact with gas, including the analysis chamber, are heated, which prevents condensation from forming inside the analyzer unit.

### EC type examination according to Directive 94/9/EC

The EuroFID is approved as a fixed gas warning device for measuring combustible gases and vapors mixed together with air. The measuring range is from 0 to 100% of the LEL. Type examination certificate: BVS 05 ATEX G 005 X.

## Versions of the EuroFID3010



Analyzer unit with control unit and terminal box



Version in industrial enclosure for Ex Zones 1 and 2

The inline version of the analyzer unit is installed directly in the process via the flange. The terminal box supplies the power to the analyzer unit. The control unit can be installed at a distance of up to 500 m from the analyzer unit. It provides a display and offers the option to enter parameters and output measured values. The EuroFID can be installed in Ex Zones 1 and 2 by

using the Ex 1 industrial enclosure. In this case, the terminal box is located in the enclosure along with the analyzer unit. The system can be fitted with an air conditioning unit. The control unit is installed in a safe area at a distance of up to 500 m from the analyzer unit.

## RELIABLE LEL MONITORING IN PROCESSES

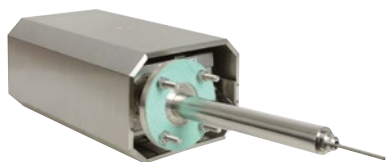

### Product description

The EuroFID3010 total hydrocarbon analyzer is a heated flame ionization detector for the determination of volatile organic compounds (VOC) in exhaust air and exhaust gas. Typical applications are

LEL monitoring in drying facilities and leak detection for solvent-filled containers. The inline analyzer can be combined with the control unit and terminal box to form a system.

### At a glance

- Gas warning device for volatile organic compounds
- Certified according to EN 50271
- Inline version for direct connection to the process
- Enclosure for use in Ex Zones 1 and 2 as an option
- Modular design for flexible installation
- Integrated dilution of sample gas
- All gas paths are heated
- No moving parts

### Your benefits

- Early warning thanks to short response time
- Measurement in corrosive gases possible
- No condensation inside the analyzer due to heating and dilution of sample gas
- Low maintenance effort due to wear-resistant design
- Direct mounting at the gas duct possible
- EC type examination as gas warning device according to 94/9/EC



### Additional information

Fields of application . . . . .	5
Detailed technical data . . . . .	5
Ordering information . . . . .	7
Dimensional drawings . . . . .	7
Connection types . . . . .	10

→ [www.mysick.com/en/EuroFID3010](http://www.mysick.com/en/EuroFID3010)

For more information, simply enter the link to get direct access to technical data, CAD design models, operating instructions, software, application examples, and much more.

## Fields of application

- Monitoring of VOC concentration in raw gas prior to exhaust air cleaning systems
- LEL measurement in the production of solvent-based products
- LEL monitoring in coating system dryers
- LEL monitoring of spray booths
- Leak detection in solvent-filled containers

## Detailed technical data

The exact device specifications and performance data of the product may deviate from the information provided here, and depend on the application in which the product is being used and the relevant customer specifications.

### System

Measured values	% LEL
TÜV-approved measurands	% LEL
Measurement principles	Flame ionisation detection
Sample quantity	40 l/h ... 170 l/h
Measuring ranges	% LEL 0 ... 100 %
Certified measuring ranges	% LEL 0 ... 100 %
Sensitivity drift	< 3 % of measuring range full scale per month
Zero point drift	< 0.5 % of measuring range full scale per month
Detection limit	< 1.5 % of measuring range full scale
Sample temperature	≤ +350 °C
Process pressure	-50 hPa ... 50 hPa
Process gas humidity	Non-condensing
Ambient pressure	800 hPa ... 1,100 hPa
Ambient humidity	5 % ... 90 % Relative humidity; non-condensing
Conformities	ISO 60079-29-1 EN 50271
Electrical safety	CE, cCSAus
Electrical connection	Voltage 115 V / 230 V Frequency 50 Hz / 60 Hz Power consumption Analyzer ≤ 230 W BCU operating unit ≤ 400 W Terminal box ≤ 275 W

### Analyzer

Description	Analyzer unit of the measuring system
Ambient temperature	0 °C ... +55 °C
Storage temperature	-25 °C ... +70 °C
Ex-approvals	ATEX Standard version: II 2/- G IIB+H2 XXX °C (XXX = 170 ... 220 °C) With industrial enclosure Ex1: II 2 G EEx p IIB+H2 XXX °C (XXX = 170 ... 220 °C)
Enclosure rating	Standard version: IP 22 With industrial enclosure Ex1: IP 65
Dimensions (W x H x D)	275 mm x 210 mm x 887 mm 596 mm x 400 mm x 844 mm (industrial enclosure Ex1)
Weight	< 25 kg Industrial enclosure Ex1: < 56 kg

<b>Electrical connection</b>	Supply via terminal box
<b>Auxiliaries</b>	
Fuel gas:	1.3 l/h ... 1.8 l/h Hydrogen 5.0; 3 ±0.3 bar; residual hydrocarbon content < 0.5 ppm
Instrument air:	360 l/h 4.0 ±0.2 bar; particle size ≤ 1 µm; particle content ≤ 1 mg/m <sup>3</sup> ; oil content ≤ 0.1 mg/m <sup>3</sup> ; water content ≤ 0.12 g/m <sup>3</sup> (pressure dew point max. 10 °C below lowest ambient temperature); hydrocarbon content ≤ 4 ppm (≤ 1 % full scale, non-fluctuating)
Reference gas:	200 l/h Typical consumption during adjustment; 8,000 ppm propane in synthetic air (LEL monitoring) or 80% of measuring range full scale; 3 ±0.3 bar
<b>Auxiliary connections</b>	Compression fitting for 6mm-tubes Compression fitting for 1/4"-tubes (US version)

## BCU operating unit

<b>Description</b>	Unit to control the system components and to evaluate and output the data provided by them
<b>Ambient temperature</b>	0 °C ... +40 °C
<b>Storage temperature</b>	-20 °C ... +60 °C
<b>Ex-approvals</b>	ATEX II (2) G
<b>Enclosure rating</b>	IP 20
<b>Analog outputs</b>	2 outputs: 0/4 ... 20 mA, 500 Ω ≤ 36 V Floating
<b>Analog inputs</b>	4 inputs: 0.25 ... 20 V
<b>Digital outputs</b>	7 FET switch: 24 V AC/DC, 100 mA For status signals
<b>Digital inputs</b>	3 floating contacts: 24 V, 10 mA Preset for lack of gas, adjustment lock and maintenance lock
<b>Interfaces</b>	RS-232c (for printer, I/O terminal strip and remote control)
<b>Indication</b>	LC display and status LEDs
<b>Operation</b>	Menu-driven operation via LC-display and membrane keyboard
<b>Dimensions (W x H x D)</b>	213 mm x 173 mm x 320 mm
<b>Weight</b>	≤ 4.5 kg

## EuroFID3010 terminal box

<b>Description</b>	Unit for connecting data cables and power supply to the system components; for potentially explosive atmospheres
<b>Ambient temperature</b>	0 °C ... +55 °C
<b>Storage temperature</b>	-25 °C ... +70 °C
<b>Ex-approvals</b>	ATEX II 3 G Ex nR II T4
<b>Enclosure rating</b>	IP 65
<b>Dimensions (W x H x D)</b>	262 mm x 395 mm x 95 mm
<b>Weight</b>	≤ 8 kg

## Terminal module V2

<b>Description</b>	Serves for connection of power supply, data and signal cabling provided by the customer
<b>Ambient temperature</b>	0 °C ... +40 °C
<b>Storage temperature</b>	-20 °C ... +60 °C
<b>Dimensions (W x H x D)</b>	158 mm x 76 mm x 48 mm
<b>Electrical connection</b>	
Voltage	24
	External power supply according SELV (EN 61140) required

## Ordering information

Our regional sales organization will help you to select the optimum device configuration.

## Dimensional drawings (Dimensions in mm (inch))

Analyzer unit

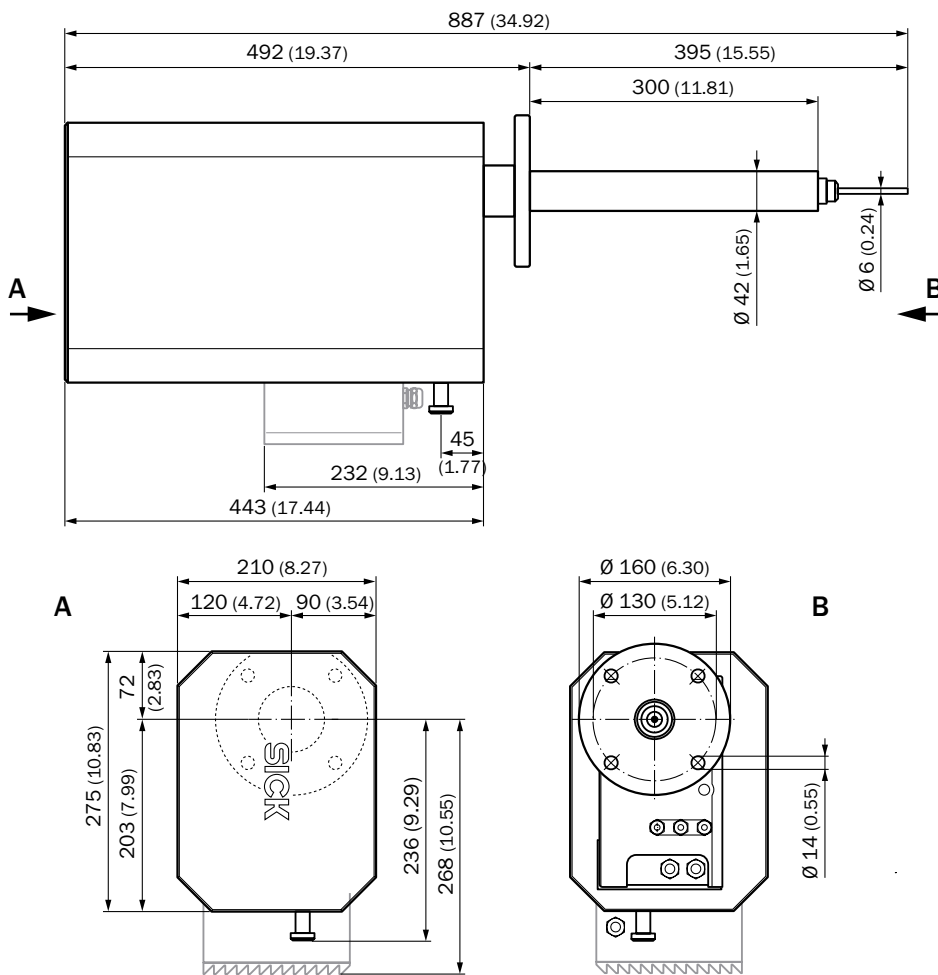

Industrial enclosure Ex1

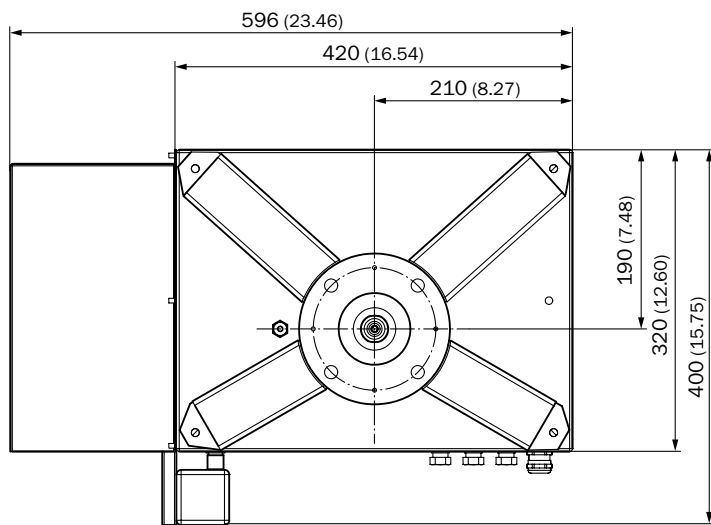
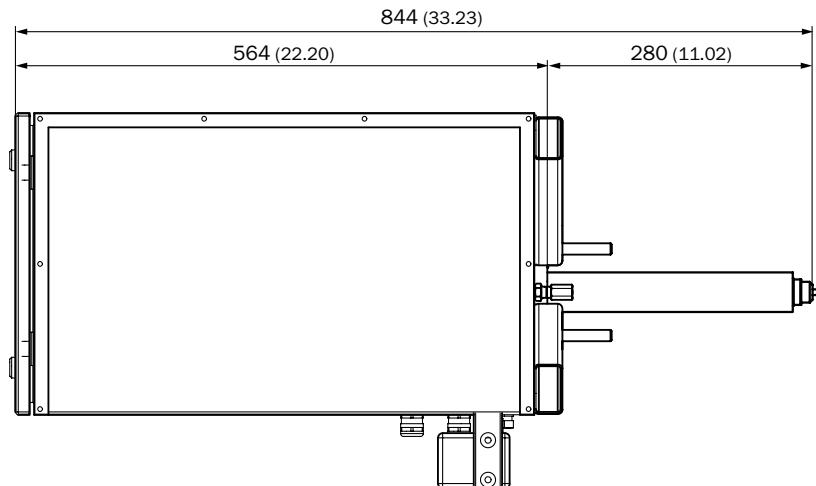

BCU operating unit

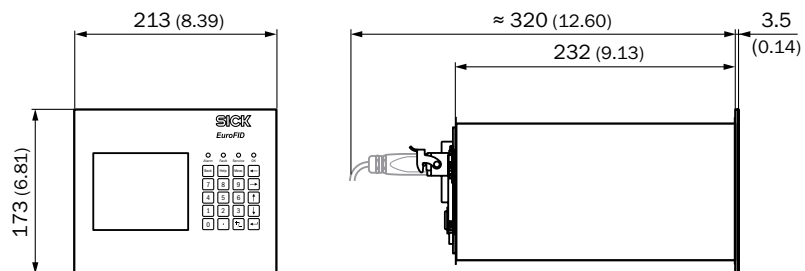



EuroFID3010 terminal box

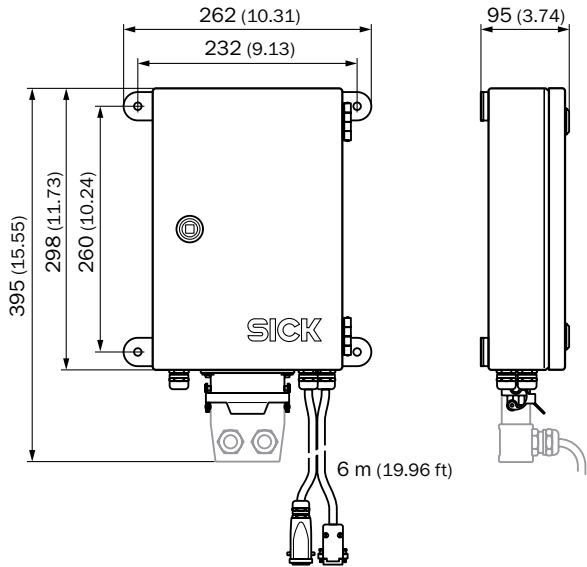

Terminal module V2

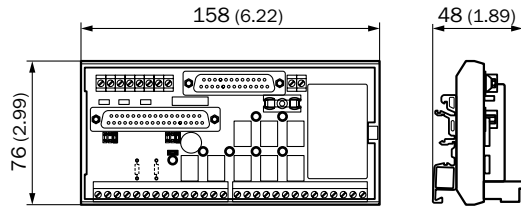

Weather hood for analyzer unit

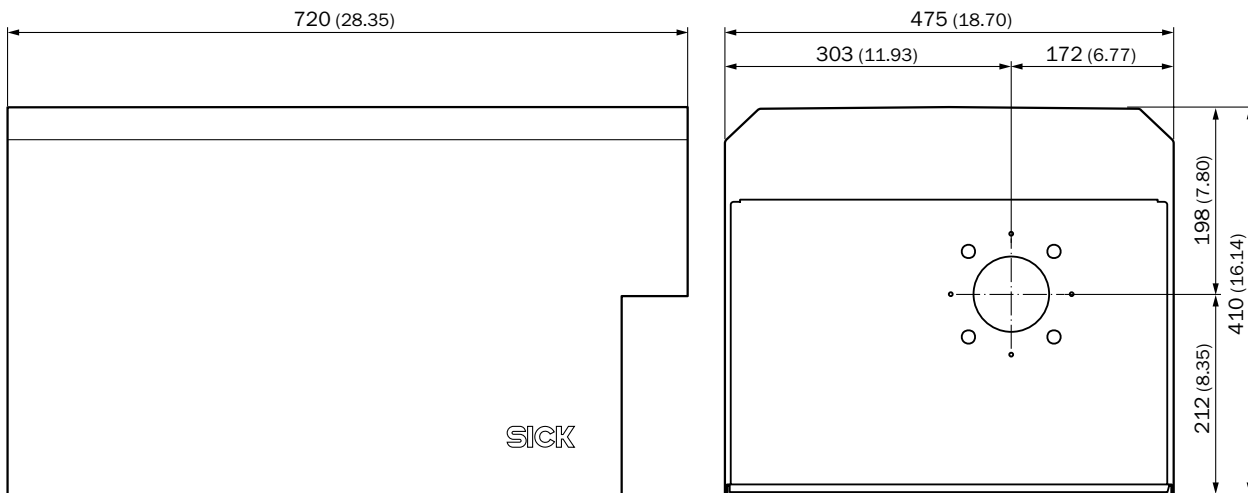

Connection types

Analyzer unit

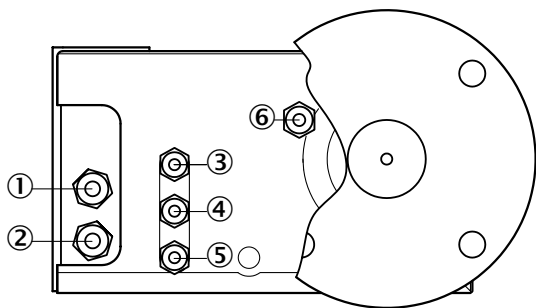

- ① Data connection
- ② Power supply
- ③ Fuel gas
- ④ Reference gas
- ⑤ Instrument air
- ⑥ Exhaust gas outlet

BCU operating unit

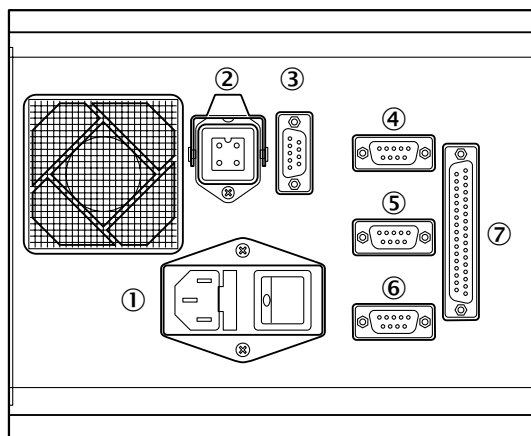

- ① Power supply
- ② Analyzer
- ③ Data connection
- ④ System
- ⑤ Printer
- ⑥ RS-232c
- ⑦ I/O (analog and digital)

## WWW.MYSICK.COM – SEARCH ONLINE AND ORDER

Search online quickly and safely - with the SICK “Finders”

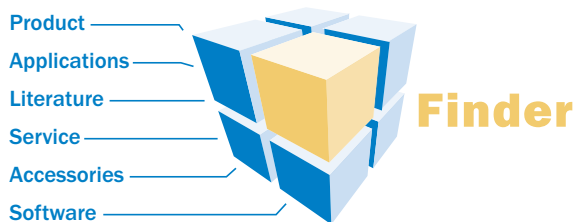

**Product Finder:** We can help you to quickly target the product that best matches your application.

**Applications Finder:** Select the application description on the basis of the challenge posed, industrial sector, or product group.

**Literature Finder:** Go directly to the operating instructions, technical information, and other literature on all aspects of SICK products.

Efficiency – with the E-Commerce-Tools from SICK



**Find out prices and availability**

Determine the price and possible delivery date of your desired product simply and quickly at any time.

**Request or view a quote**

You can have a quote generated online here. Every quote is confirmed to you via e-mail.

**Order online**

You can go through the ordering process in just a few steps.

## FOR SAFETY AND PRODUCTIVITY: SICK LIFETIME SERVICES

SICK LifeTime Services is a comprehensive set of high-quality services provided to support the entire life cycle of products and applications from system design all the way to upgrades. These services increase the safety of people, boost the productivity of machines and serve as the basis for our customers’ sustainable business success.



**Consulting & Design**

Globally available experts for cost-effective solutions



**Product & System Support**

Fast and reliable, by telephone or on location



**Verification & Optimization**

Checks and recommendations for increased availability



**Upgrade & Retrofits**

Uncovers new potential for machines and systems



**Training & Education**

Employee qualification for increased competitiveness

## SICK AT A GLANCE

SICK is a leading manufacturer of intelligent sensors and sensor solutions for factory, logistics, and process automation. With more than 6,000 employees and over 40 subsidiaries worldwide, we are always close to our customers. A unique range of products and services creates the perfect basis for controlling processes securely and efficiently, protecting individuals from accidents and preventing damage to the environment.

We have extensive experience in various industries and understand their processes and requirements. With intelligent sensors, we can deliver exactly what our customers need. In application centers in Europe, Asia and North America, system solutions are tested and optimized in accordance with customer specifications. All this makes us a reliable supplier and development partner.

Comprehensive services round out our offering: SICK LifeTime Services provide support throughout the machine life cycle and ensure safety and productivity.

**For us, that is “Sensor Intelligence.”**

### **Worldwide presence:**

Australia, Austria, Belgium/Luxembourg, Brazil, Czech Republic, Canada, China, Denmark, Finland, France, Germany, Great Britain, Hungary, India, Israel, Italy, Japan, Mexico, Netherlands, Norway, Poland, Romania, Russia, Singapore, Slovenia, South Africa, South Korea, Spain, Sweden, Switzerland, Taiwan, Turkey, United Arab Emirates, USA

Please find detailed addresses and additional representatives and agencies in all major industrial nations at: [www.sick.com](http://www.sick.com)